

## Cisco Video Surveillance 4000 Series High-Definition IP Cameras

Cisco® Video Surveillance 4000 Series IP Cameras are high-definition, feature-rich digital cameras designed for superior performance in a wide variety of video surveillance applications. The cameras employ true high-definition (HD) video and H.264 compression, streaming up to 30 frames per second (fps) at 1080p (1920 x 1080) resolution, and 60 fps at 720p (1280 x 720) resolution, offering efficient network utilization with the highest-quality video. Contact closures and two-way audio allow integration with microphones, speakers, and access control systems. With its open, standards-based design, the camera provides an ideal platform for integration and operation as an independent device or as part of a Cisco Video Surveillance network.

The Cisco Video Surveillance 4300 and 4500 IP Cameras have identical feature sets, with the exception of the additional digital signal processor (DSP) capabilities specifically designed to support real-time video analytics at the edge on the 4500 IP Camera. On this model, applications and end users have the option to run multiple analytics packages without compromising video streaming performance on the camera. This highly flexible computing platform is ideal for next-generation video analytics applications.

**Figure 1.** IP Camera Shown with Optional DC Auto Iris Lens, Available Separately



The Cisco Video Surveillance 4000 Series IP Camera offers a variety of benefits, including:

- **True high-definition video.** The camera streams crisp and clear 1080p (1920 x 1080) video at 30 frames per second while maintaining surprisingly low network bandwidth. For fast motion applications, the camera can be set to stream 720p (1280 x 720) video at 60 frames per second.
- **Progressive scan video.** The camera captures each frame at its entire resolution using a progressive scan rather than interlaced video capture, which captures each field of video. This feature allows for better detail for video of moving objects, such as faces and license plates on automobiles.
- **Dual streaming.** The camera can stream H.264 and MJPEG video simultaneously. Each video stream can be configured with individual resolution, quality, and frame rate settings.
- **Day/night operation.** The camera provides true day/night functionality, and includes an IR filter that automatically switches to night mode in low-light scenes. This function can be set to manual, automatic, or scheduled control.
- **Flexible power options.** The camera supports Power over Ethernet (PoE) 802.3af, 12 VDC or 24 VAC power through an optional external power supply.

- **Mounting options.\*** The camera can be installed with a fixed mount or with an optional external pan/tilt mount and motorized zoom lens.
- **Embedded security and networking.\*** The camera provides hardware-based Advanced Encryption Standard (AES). For enhanced bandwidth management, the camera supports IP Multicast.
- **Event notification.\*** The camera can examine designated areas for activity and notify users or other applications when it detects activity that exceeds a predefined sensitivity and threshold. The camera also provides two digital inputs and two digital outputs that can be used to initiate specific actions when an alarm is detected.
- **Medianet support.** The camera supports the medianet interface. When connected to a Cisco switch that also supports medianet, the camera is recognized as a video endpoint by the switch, which then uses SmartPort Macros to set the right network parameters for the video stream on the network.
- **Video analytics support:** The 4500 IP camera provides real-time, edge-based video analytics capabilities.

**Note:** Features with an asterisk are not available when the camera is used with Cisco Video Surveillance Manager.

## Features

Table 1 describes the features of the Cisco Video Surveillance 4000 Series IP Camera.

**Table 1.** Cisco Video Surveillance 4000 Series IP Camera Features

Item	Specification
<b>Imaging Device</b>	1/3-in. progressive-scan RGB CMOS
<b>Image Control</b>	Automatic white balance (AWB), automatic gain control (AGC), automatic exposure (AE), and auto/manual iris
<b>Dynamic Range</b>	65 dB
<b>Minimum Illumination</b>	<ul style="list-style-type: none"> <li>• Color mode: F1.4 @ 0.4 lux</li> <li>• Black and white mode: F1.4 @ 0.2 lux</li> </ul>
<b>Signal-to-Noise Ratio (SNR)</b>	53 dB
<b>Lens Selection</b>	Accepts manual or DC auto iris lens
<b>Lens Mount</b>	<ul style="list-style-type: none"> <li>• CS mount</li> <li>• C mount, with provided adapter</li> </ul>
<b>Shutter Speed</b>	Electronic Rolling Shutter (ERS)
<b>Video Compression</b>	H.264, MJPEG
<b>Audio Compression*</b>	G.711 A-Law, G.711 U-Law, AAC
<b>Resolution and Frame Rate (H.264)</b>	<ul style="list-style-type: none"> <li>• 1920 x 1080 @ 30 fps (1080p)</li> <li>• 1280 x 720 @ 60 fps (720p)*</li> <li>• 720 x 480/576 @ 30/25 fps (D1)</li> <li>• 704 x 480/576 @ 30/25 fps (4CIF)</li> <li>• 352 x 240/288 @ 30/25 fps (CIF)</li> </ul>
<b>Resolution and Frame Rate (MJPEG)</b>	<ul style="list-style-type: none"> <li>• 720 x 480/576 @ 30/25 fps (D1)</li> <li>• 704 x 480/576 @ 30/25 fps (4CIF)</li> <li>• 352 x 240/288 @ 30/25 fps (CIF)</li> </ul>
<b>Video Streaming</b>	<ul style="list-style-type: none"> <li>• Single-stream H.264 up to 1080p (1920 x 1080) @ 30 fps</li> <li>• Dual-stream H.264 and MJPEG <ul style="list-style-type: none"> <li>◦ H.264: Primary stream programmable up to 1280 x 720 @ 25/20 fps</li> <li>◦ MJPEG: Secondary stream programmable up to 720 x 576 @ 25/20 fps</li> </ul> </li> </ul>
<b>Protocols*</b>	Dynamic Host Control Protocol (DHCP), Hypertext Transfer Protocol (HTTP), Secure HTTP (HTTPS), Network Time Protocol (NTP), Real-Time Transport Protocol (RTP), Real-Time Streaming Protocol (RTSP), Simple Mail Transfer Protocol (SMTP), Secure Sockets Layer/Transport Layer Security (SSL/TLS), Transmission Control Protocol/Internet Protocol (TCP/IP), Secure Real-Time Transport Protocol (SRTP), Cisco Discovery Protocol, Bonjour, Simple Network Management Protocol (SNMP), and Secure Shell (SSH)

Item	Specification
<b>Quality of Service (QoS)*</b>	Differentiated services code point (DSCP) marking, class of service (CoS) marking
<b>Power</b>	12 VDC or 24 VAC through optional external power supply, available separately PoE (802.3af) @ 48V/0.3A
<b>Power Consumption</b>	4300 IP Camera: 11W (max) 4500 IP Camera: 11.5W (max)

\*Not supported when the camera is used with Cisco Video Surveillance Manager.

Table 2 lists the video stream support for the Cisco Video Surveillance 4000 Series.

**Table 2.** Cisco Video Surveillance 4000 Series Video Stream Support

Resolution	Primary (fps)	Secondary (fps)*					
<b>1080p</b>	Any	Secondary stream not supported if resolution is 1080p					
<b>720p or Lower</b>	60	Secondary stream not supported if primary is at 60fps					
<b>720p or Lower</b>	30	30	15	10	5	3	1
<b>720p or Lower</b>	25	25	13	5	1	–	–
<b>720p or Lower</b>	20	20	10	5	1	–	–
<b>720p or Lower</b>	15	15	8	5	3	1	–
<b>720p or Lower</b>	10	10	5	1	–	–	–
<b>720p or Lower</b>	8	8	–	–	–	–	–
<b>720p or Lower</b>	6	6	–	–	–	–	–

\* If a secondary frame rate is selected in Cisco Video Surveillance Manager that is not listed in this table, the camera will automatically use the closest frame rate.

## Connectors

Table 3 describes the connectivity and connectors of the Cisco Video Surveillance 4000 Series IP Camera.

**Table 3.** Cisco Video Surveillance 4000 Series IP Camera Connectors

Item	Specification
<b>Network Connectivity</b>	10/100 BASE-TX Ethernet with RJ-45 connector
<b>Audio*</b>	<ul style="list-style-type: none"> <li>1, 3.5-mm input/output jack for optional external speaker and optional external microphone via Y-cable</li> <li>Built-in microphone* Two-way (full-duplex)</li> </ul>
<b>Serial Port*</b>	RS-232, Pelco D protocol only
<b>Alarm Input*</b>	2, logic level programmable
<b>Alarm Output*</b>	2, logic level programmable
<b>Power Input</b>	3-pin terminal

\*Not supported when the camera is used with Cisco Video Surveillance Manager.

## Software

Table 4 describes the primary features of the Cisco Video Surveillance 4000 Series IP Camera software.

**Table 4.** Cisco Video Surveillance 4000 Series IP Camera Primary Software Features

Item	Specification
<b>Activity Detection</b>	User-definable alerts with configurable sensitivities and thresholds, e-mail alert, and HTTP notifications
<b>Video Format</b>	NTSC and PAL
<b>Image Settings</b>	Configurable brightness, sharpness, contrast, saturation, hue, and white balance
<b>Overlay Capabilities</b>	Time, date, and text
<b>Selectable Bit Rate</b>	Support for Constant Bit Rate or Variable Bit Rate* (constant quality)

Item	Specification
<b>IP Filtering*</b>	Users can enter a list of allowed or blocked IP addresses for viewing video and configuring camera settings
<b>Discovery</b>	Cisco Discovery Protocol, Bonjour Zero-Configuration discovery
<b>Configuration</b>	<ul style="list-style-type: none"> <li>• Browser-based using Internet Explorer 6.x, SP2 and above</li> <li>• Two levels of user access with password protection</li> </ul>
<b>Video Analytics</b>	4500 IP Camera includes a fully programmable DSP-based analytics co-processor. The camera comes pre-loaded with a Base Analytics package. Please refer to the Cisco Video Analytics datasheet for more information.

\*Not supported when the camera is used with Cisco Video Surveillance Manager.

## Specifications

Table 5 provides specifications of the Cisco Video Surveillance 4000 Series IP Camera.

**Table 5.** Cisco Video Surveillance 4000 Series IP Camera Mechanical Specifications

Item	Specification			
<b>Housing</b>	Aluminum			
<b>LEDs</b>	Power, Ethernet link, and activity			
<b>Dimensions (L x W x H)</b>	<ul style="list-style-type: none"> <li>• 5.2 x 3.1 x 2.5 in.</li> <li>• 135 x 79.5 x 65 mm</li> </ul>			
<b>Weight</b>	4300 IP Camera: <ul style="list-style-type: none"> <li>• 1.2 lb</li> <li>• 0.54 kg</li> </ul> 4500 IP Camera: <ul style="list-style-type: none"> <li>• 1.25 lb</li> <li>• 0.56 kg</li> </ul>			
<b>Certifications</b>	<table border="0"> <tr> <td style="vertical-align: top;"> <b>Safety:</b> IEC 60950-1 (2005) Second edition               </td> <td style="vertical-align: top;"> <b>EMC-Emissions:</b> 47 CFR Part 15 CISPR22 EN300386: V1.3.3 EN55022 EN61000-3-2 EN61000-3-3 ICES-003 Issue 4 KN 22 VCCI: V-3 CNS-13438 EN 55024               </td> <td style="vertical-align: top;"> <b>EMC-Immunity:</b> CISPR24 EN300386: V1.3.3 EN50082-1 EN50082-1 EN55024 EN61000-6-1               </td> </tr> </table>	<b>Safety:</b> IEC 60950-1 (2005) Second edition	<b>EMC-Emissions:</b> 47 CFR Part 15 CISPR22 EN300386: V1.3.3 EN55022 EN61000-3-2 EN61000-3-3 ICES-003 Issue 4 KN 22 VCCI: V-3 CNS-13438 EN 55024	<b>EMC-Immunity:</b> CISPR24 EN300386: V1.3.3 EN50082-1 EN50082-1 EN55024 EN61000-6-1
<b>Safety:</b> IEC 60950-1 (2005) Second edition	<b>EMC-Emissions:</b> 47 CFR Part 15 CISPR22 EN300386: V1.3.3 EN55022 EN61000-3-2 EN61000-3-3 ICES-003 Issue 4 KN 22 VCCI: V-3 CNS-13438 EN 55024	<b>EMC-Immunity:</b> CISPR24 EN300386: V1.3.3 EN50082-1 EN50082-1 EN55024 EN61000-6-1		
<b>Operating Temperature</b>	Indoors: <ul style="list-style-type: none"> <li>• 32 to 122°F</li> <li>• 0 to 50°C</li> </ul> Outdoors (when installed in an appropriate outdoor enclosure with heating and cooling): <ul style="list-style-type: none"> <li>• -40 to 158°F</li> <li>• -40 to 70°C</li> </ul>			

Figure 2 shows the dimensions of the Cisco Video Surveillance 4000 Series IP Cameras.

**Figure 2.** Cisco Video Surveillance 4000 Series IP Camera Dimensions

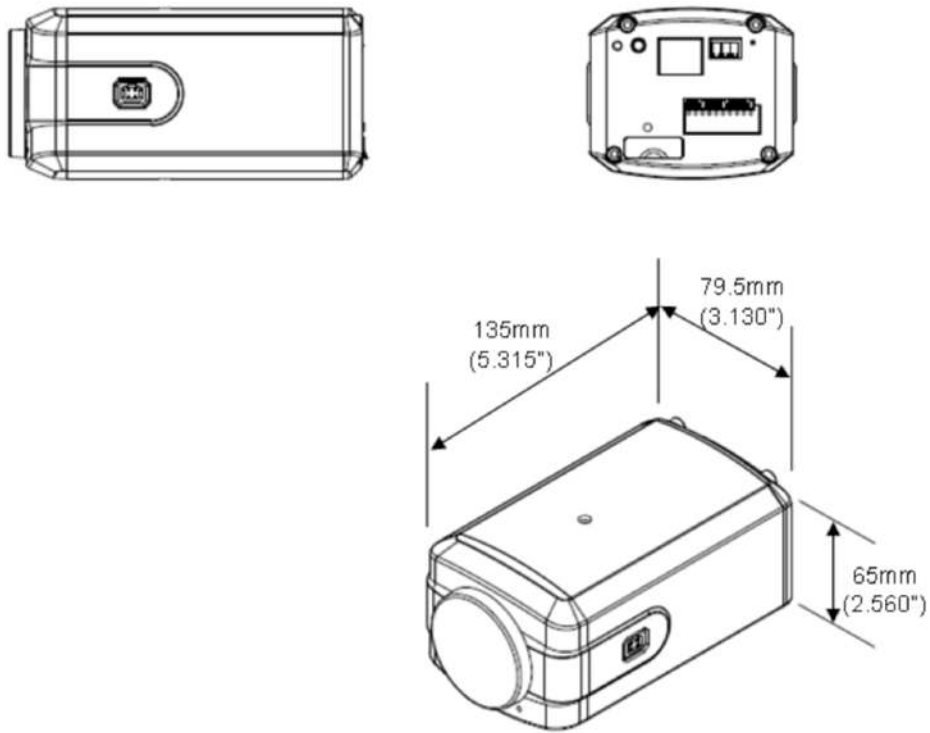

**Package Contents**

Table 6 describes the items that ship with the Cisco Video Surveillance 4000 Series IP Camera.

**Table 6.** Package Contents

Item
Cisco Video Surveillance 4000 Series IP Camera
Regulatory compliance and safety information
Quick start guide
Accessories: Lens-opening dust cap, terminal block for power connection, C mount lens adaptor, 0.9-mm Allen wrench, Y-cable for audio, port cover

**Availability**

The Cisco Video Surveillance 4000 Series IP Camera is available through Cisco Authorized Technology Provider (ATP) Partners.

**Ordering Information**

Table 7 lists the part numbers for the Cisco Video Surveillance 4000 Series IP Camera and for the lenses that the camera supports.

**Table 7.** Ordering Information

Part Number	Description
<b>CIVS-IPC-4300</b>	Cisco Video Surveillance 4300 IP Camera, HD, Day/Night
<b>CIVS-IPC-4500</b>	Cisco Video Surveillance 4500 IP Camera, HD, DSP, Day/Night
<b>CIVS-PWRPAC-12V</b>	12 VDC @ 1.6A Power Supply

Part Number	Description
<b>Lenses</b>	
<b>CIVS-IPC-VFM28-12</b>	Cisco IP Camera Megapixel Lens, 2.8–12 mm, Fujinon
<b>CIVS-IPC-VFM15-50</b>	Cisco IP Camera Megapixel Lens, 15–50 mm, Fujinon
<b>CIVS-IPC-VTM38</b>	Cisco IP Camera Lens Megapixel 3-8mm Tamron
<b>CIVS-IPC-VTM55</b>	Cisco IP Camera Lens Megapixel 5-50mm Tamron

## Using the Camera with Cisco Video Surveillance Manager

Features that are marked with an asterisk (\*) are not supported when using the camera with Cisco Video Surveillance Manager. Please refer to the Release Notes for Cisco Video Surveillance Manager 4.2/6.2 for more information:

[http://www.cisco.com/en/US/docs/security/physical\\_security/video\\_surveillance/network/media\\_server/6\\_2/release\\_notes/rn42\\_62.pdf](http://www.cisco.com/en/US/docs/security/physical_security/video_surveillance/network/media_server/6_2/release_notes/rn42_62.pdf)

## Services and Support

Cisco and our certified partners can help you accelerate success and improve the return on your investment in a Cisco Physical Security solution. The Cisco lifecycle approach to services defines the requisite activities at each phase of the solution lifecycle:

- Reduce deployment costs by identifying the features that will best meet your business requirements
- Accelerate migration by assessing the readiness of your network to support the system and by developing a sound design
- Support smooth implementation through effective planning and expert installation, configuration, and integration
- Increase operational efficiency and extend the value of your investment with award-winning technical support

For more information about Cisco services, visit <http://www.cisco.com/go/services>.

## For More Information

For more information about the Cisco Video Surveillance 4000 Series IP Camera, visit <http://www.cisco.com/go/videosurveillance> or [contact your local account representative](#).



**Americas Headquarters**  
Cisco Systems, Inc.  
San Jose, CA

**Asia Pacific Headquarters**  
Cisco Systems (USA) Pte. Ltd.  
Singapore

**Europe Headquarters**  
Cisco Systems International BV Amsterdam,  
The Netherlands

Cisco has more than 200 offices worldwide. Addresses, phone numbers, and fax numbers are listed on the Cisco Website at [www.cisco.com/go/offices](http://www.cisco.com/go/offices).

Cisco and the Cisco Logo are trademarks of Cisco Systems, Inc. and/or its affiliates in the U.S. and other countries. A listing of Cisco's trademarks can be found at [www.cisco.com/go/trademarks](http://www.cisco.com/go/trademarks). Third party trademarks mentioned are the property of their respective owners. The use of the word partner does not imply a partnership relationship between Cisco and any other company. (1005R)